

ADJUSTING ARMSTRONG LEVER SHOCK ABSORBERS

Armstrong lever arm shocks are available in a variety of damping grades. The variations are made primarily in the valving. The way these devices work is that there are two pistons pushing oil back and forth through an orifice. This orifice is small, so there is resistance to flow due to the viscosity of the oil in the piston chambers. If the size of the connecting hole was not allowed to vary, the damping would be VERY strong for sudden jolts. It would be so strongly damped that it would be rigid for all practical purposes. In order to accommodate sudden jolts, the oil is allowed to force its way past the small orifice through a larger spring-loaded valve. There are actually two separate valves in the valve assembly. One to control the upward jolts (bounce) (#13 in the diagram) and another to control the downward return of the suspension to its rest position (#15).

The springs (#17,18) adjust the damping. When these units were new, there were alternate compression springs available. Kastner said that certain shocks had as standard a steel (grey) colored compression spring, but other shocks had a bright copper colored spring as standard. Mine have the bright copper springs. The "competition" spring has a dull copper or bronze color. I have seen none of these competition springs available nor do I know the various spring strengths to try to get new ones. There are "heavy duty" valve assemblies for certain cars, but none that I know of for the TR's, and I doubt that they are completely interchangeable.

In order to adjust damping today, we can tighten the nut holding the rebound spring and insert spacers (washers) under the compression spring. I have two sources that pretty much agree on what modifications to make. First use 20w oil for the hydraulic fluid. Next adjust the springs. I have been told to use fork oil because engine oil has detergents which will damage the rubber seals, and the fork oil has anti-foaming additives to cut down foam when stressed to the max. A good choice is Penrite Shock Absorber Oil n° 2.

My first source says to tighten the nut on the rebound spring "all the way down", and install a 0.070" (ca. 1,8 mm.) spacer under the compression spring at the bottom of the bore.

My other source says to tighten the nut on the rebound spring 2 to 4 full turns, and a spacer of 0.040" (ca. 1 mm.) to 0.080" (ca. 2 mm.) under the compression spring. Select the amount of adjustment depending on how much damping you want. I decided to try settings near the maximum and ease off from there if they were too harsh or if there was some other problem.

My experience is limited, but successful. I tightened the rebound spring nut by 4 turns (which is almost all the way down). I used 2 brass washers under each compression spring. The washers were obtained from my local hardware store for about 15 cents each. They measured just over 1/2" (12,7 mm.) diameter and 0.038" (ca. 1 mm.) thickness. I used a file to smooth and slightly thin the washers. I had to ream the center holes large enough to easily pass the rebound spring. The four washers were matched in pairs and I got 0.073" (ca. 1,8 mm.) combined thickness on each side. The outer diameter of the washers was 0.563" (ca. 14,3 mm.), and the inner diameter was 0.322" (ca. 8,2 mm.).

I have found that the damping is quite nice. I am using the TriumphTune 4212 rear springs (420 lbs/inch and about stock ride height). This combination seems very satisfactory: good damping without being harsh.

Anthony Rhodes

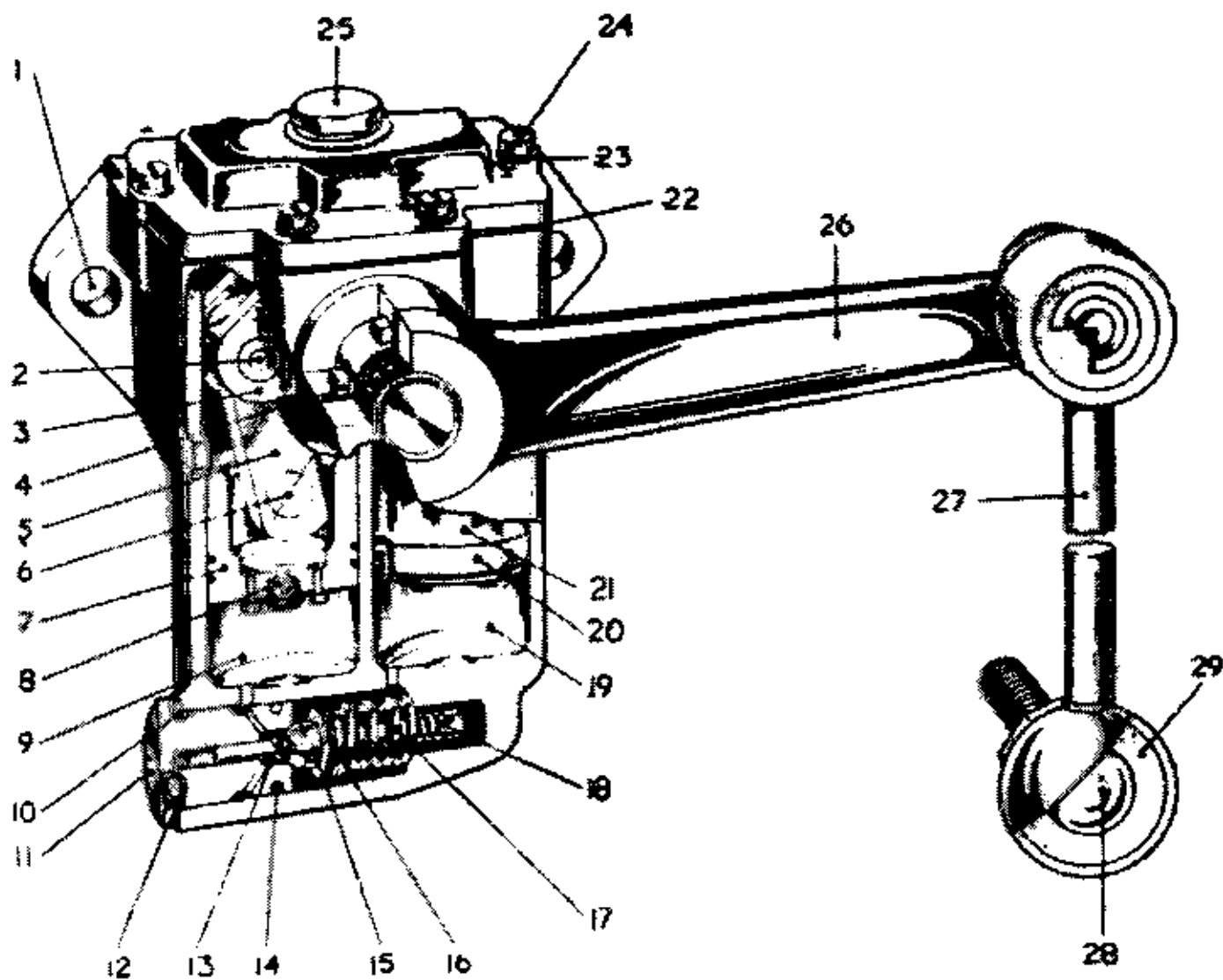

Fig. 11.15. REAR SHOCK ABSORBER COMPONENTS

- | | | | |
|------------------------------|--------------------------------|------------------------|--------------------|
| 1 Mounting holes | 9 Compression or bump cylinder | 15 Compression washer | 24 Lid screw |
| 2 Crank pin | 10 Ring seal | 17 Compression spring | 25 Filler plug |
| 3 Crank pin | 11 Valve screw | 18 Rebound spring | 26 Arm |
| 4 Oil seal | 12 Valve screw washer | 19 Rebound cylinder | 27 Connecting link |
| 5 Connecting rod | 13 Rebound valve | 20 Rebound piston seal | 28 Ball end bolt |
| 6 Piston pin | 14 Ring seal | 21 Rebound piston | 29 Rubber cushion |
| 7 Compression or bump piston | 15 Compression valve | 22 Gasket | |
| 8 Recuperating valve | | 23 Shakeproof washer | |